

# *More Than Tooling Resins: A Wide Variety of Solutions for Foundry Tooling*

*tooling resins   blocks   ancillaries   silicones*

***ebalta***  
*Solution takes shape*

## *Tooling resins mean the world to us. Foundry tooling is our success story.*

*Everything began back in 1974: with the founding of **ebalta**, high-performance tooling resins began to rapidly take hold in this field – along with a new standard in customer support that continues to set the standard for excellence to this very day. The result: a long-standing success story and unsurpassed expertise in foundry tooling.*



### *Performance:*

#### *a wide variety of solutions is our forté*

As a provider of polyurethane and epoxy resin systems and machinable block and board materials, **ebalta** has achieved a high degree of expertise and experience during its more than 30 years of development and production, along with an uncontested position within the foundry tooling market.

Our most important credo on our path to success has been customer support. By working closely with our clients, maintaining a continuous exchange of information with them and constantly optimising our products, we have been able to amass a wide spectrum of individual solutions and newer, higher-performance technologies. Regardless of the task at hand: together we can find the right solution for you, one perfectly suited to your needs.

## Customers are people. And not profit sheets.

*What counts is your satisfaction. From our very first intensive consultation for the choice of product, to our continuous collaboration into the foundry, our international sales partners are on your side. Together with you, we will work on any material or process until your model comes out the way you want it: perfect.*

### *Our experience brings you more: a complete product portfolio*

The variety of specific demands determines the variety of available products: at **ebalta**, you will find all the materials you need to meet the demands of foundry tooling. All these materials exhibit high abrasion resistance and dimensional accuracy, properties that make them particularly valuable in this field. Our experts will be glad to advise you how to handle the materials properly.

- **Epoxy and polyurethane-based casting resins:** For highly abrasion resistant series models and core boxes
- **Resin systems:** For high-volume foundry patterns and back-filling
- **ebablock®:** Net-sized contour block materials available in individual dimensions and shapes
- **ebaboard:** Board materials available in various thicknesses
- **eba•ject** and **eba•safe:** Patented ejector system and fastening system
- **Processing auxiliaries from ebalta:** Comprehensive range of adhesives for board materials, repairing pastes, fillers, release agents, sealers etc.

### *Fast, guaranteed: worldwide distribution network*

No matter what your request might be: **ebalta** will deliver your product quickly and reliably – including customer support, order assembly and shipping – so that you can concentrate on what's important to you: foundry patterns.

### *Special jobs require specialised know-how*

We want your solutions to work. At **ebalta**, you will work together with experienced designers, master model-makers and foundry engineers to solve all your application and production issues. You benefit through our experts: people who understand your problems well and know how to fix them.

### *Your demand is our challenge*

You have the job, we have the experience and the material – perfectly matched to meet your individual needs, tested in accordance with all quality standards by our own laboratory, and technically flawless. Our team of experts will provide you with all the help you need in selecting your materials. If you want, they will also assist you in the manufacturing of your model.



## *Always sound advice. Especially about the right product.*

*With the variety of materials and products available in the field of foundry tooling, numerous factors have to be considered when choosing materials. The following pages offer you both orientation and overview. If you need any further advice, just ask us.*

### *Flexible for any job: our products*

Economical, fast, precise: the demands made on foundry patterns are enormous and rapidly growing. **ebalta** offers you a wide range of products, including epoxy and polyurethane resin systems as well as board and block materials. Each product possesses different properties, depending on the requirements. The following questions can assist in determining the right choice of materials:

- What is supposed to be manufactured: a model, a core box or a negative?
- How many units does it need to produce?
- What size?
- What process (high pressure forming, multi-punch presses etc.) and/or core making process, e.g. cold box will be used?



### *Individual advice for your job*

No matter what your question or application is, just ask our international sales partners. They recommend the right product or create your own individual tooling resin. They are happy to work with you on site at your facility for as long as it takes to get your model right.

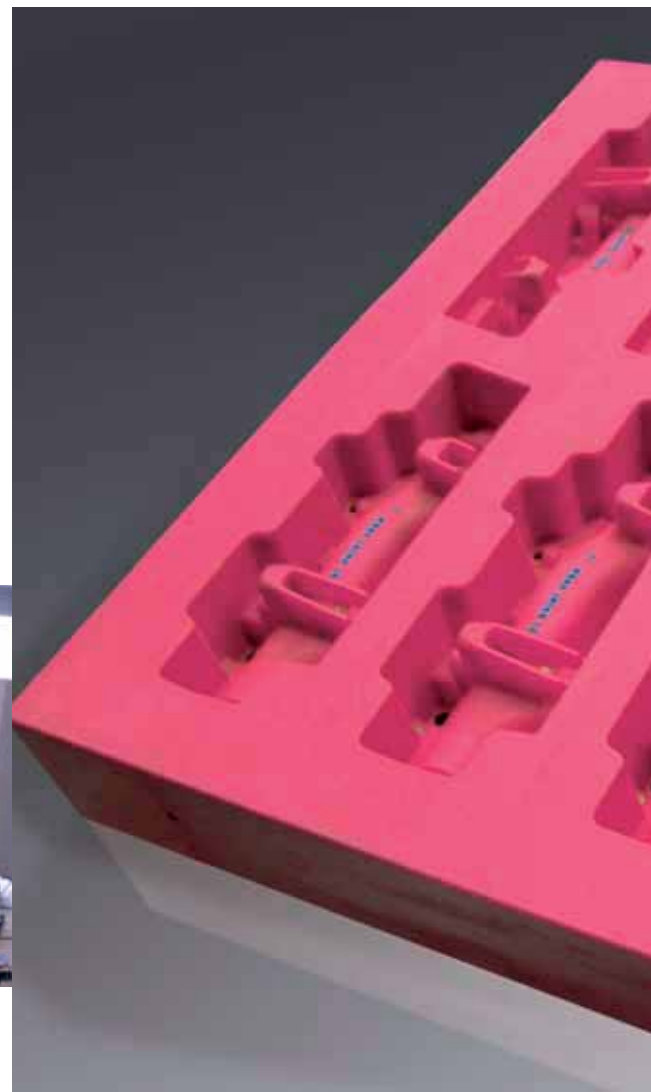

# Individual jobs need individual solutions. And a flexible product range.

Anytime individual solutions are required, a flexible product range is the best foundation. **ebalta** offers a broad spectrum of specialised services and products for foundry tooling that meets all specific requirements, including expert customer support.

## Custom solutions for your job

**ebalta** has the right material and an economical solution for any job. Our team can tell you exactly which product is the right one for your application. You can find all of our products for the most diverse manufacturing techniques on pages 6-19 as well as an overview in the index.

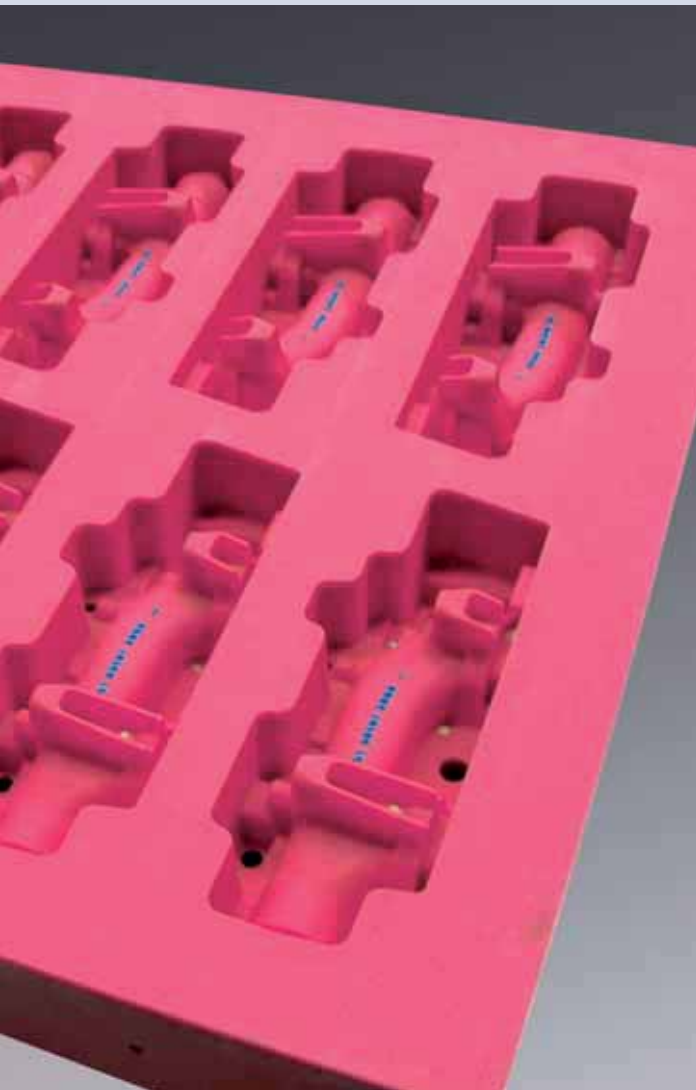

## Index

■ <b>Product recommendations for various manufacturing processes</b> .....	<b>6-10</b>
Cast and laminated patterns .....	<b>6</b>
Milled patterns .....	<b>7</b>
Cast and laminated core boxes .....	<b>8</b>
Milled core boxes .....	<b>9</b>
Negatives .....	<b>10</b>
■ <b>Products and specifications</b> .....	<b>11-19</b>
Gel coats .....	<b>11</b>
General purpose resins and paste systems .....	<b>12</b>
Epoxy casting resins .....	<b>13</b>
Polyurethane casting resins .....	<b>14</b>
Fast casting resins .....	<b>15</b>
<b>ebaboard</b> : boards for foundry patterns .....	<b>16</b>
<b>ebablock</b> ®: the net-sized contour block material for jointless foundry patterns .....	<b>17-19</b>
■ <b>Other products by ebalta</b> .....	<b>20-23</b>
<b>eba-ject</b> ejector system .....	<b>20</b>
<b>eba-safe</b> fastening system .....	<b>21</b>
<b>ebalta</b> production aids .....	<b>22</b>
Ancillaries from <b>ebalta</b> .....	<b>23</b>

# Product recommendations for various manufacturing processes

## Cast and laminated patterns

Which product is suitable for manufacturing cast pattern depends on the size of the model and the unit count. Whether it's a solid casting, face casting or lay-up process: all **ebalta** products are superbly user-friendly and have stood the test of time. Further benefits include high dimensional accuracy and low sand build-up.

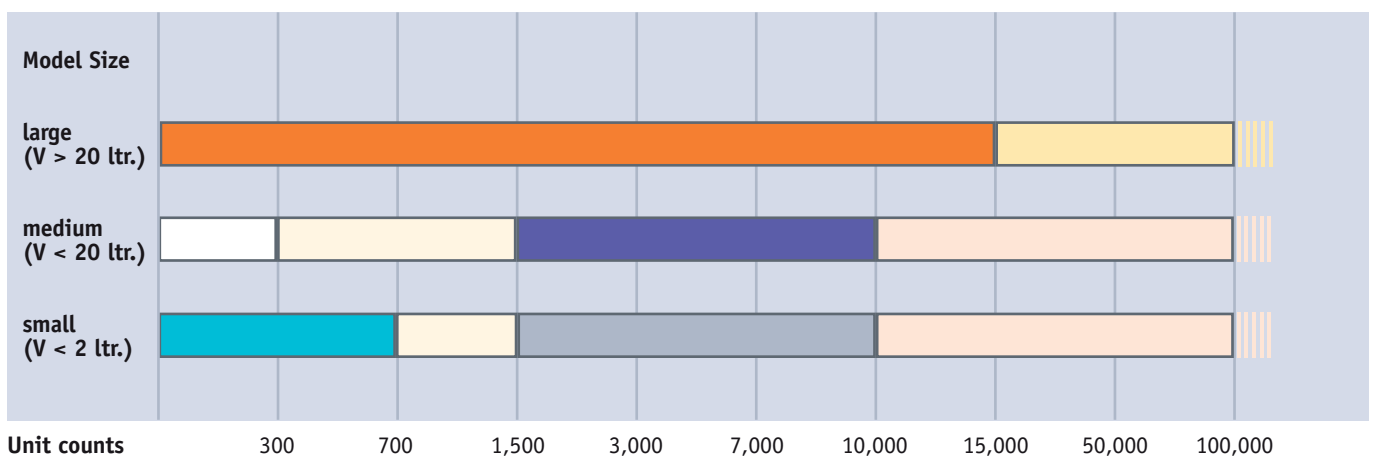

Unit counts are non-binding and based on manufacturing process. For further possible applications of products and their detailed technical data, please see pages 11-15.

### Volume > 20 Litres

- Model, laminated: OH 11, OH 6-1 with KP 6 and PS 03
- Model, laminated: OH 17 with KP 6 and PS 03

### Volume < 20 Litres

- Model, back-filled: OH 4 with KP 6 and GM 725-7
- Solid casting, slow curing: GM 725-7
- Face casting: GH 760, GH 730, GH 706
- Face casting: GM 975, VP GM 995

### Volume < 2 Litres

- Solid casting, fast curing: SG 130, SG 2000, SG 700
- Solid casting, slow curing: GM 725-7
- Solid casting: GH 760
- Face casting: GM 975, VP GM 995



Pattern made of GM 725-7



Pattern made of GH 760

## Milled patterns

*ebalta offers a broad spectrum of products for milled patterns where the choice of materials is based on the unit count. You can find the optimal solution for any unit count you require. Highest precision thanks to CNC technology and high abrasion resistance. Totally innovative: **ebablock**<sup>®</sup>, a block material prefabricated to your individual specifications.*

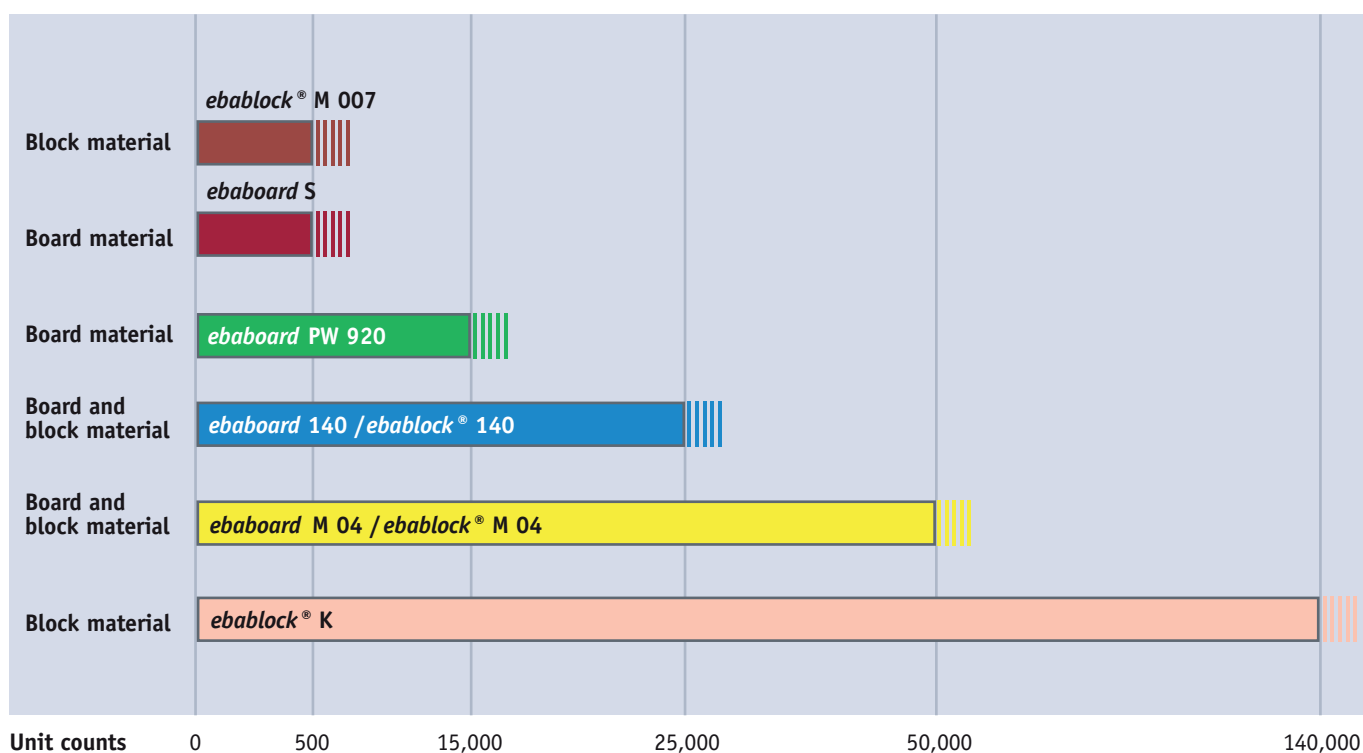

*Unit counts are non-binding and based on manufacturing process. For specifications and other technical information, please see pages 16-17.*

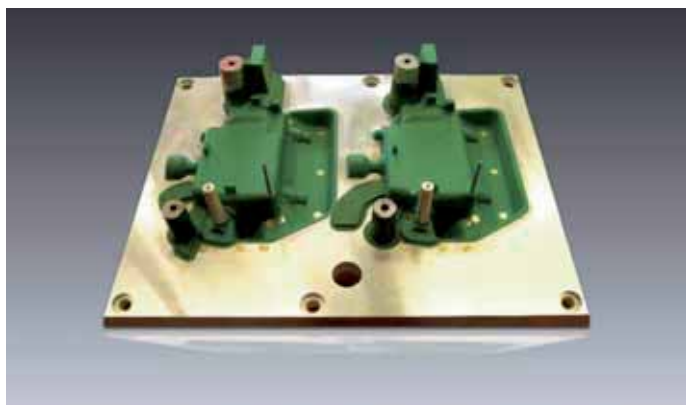

Pattern made of **ebaboard** PW 920



Pattern made of **ebablock**<sup>®</sup> M 04

## Cast and laminated core boxes

Unit count and model size determine the choice of material for cast core boxes. Whether it's a solid casting, face casting or lay-up process – **ebalta** products are extremely abrasion resistant, withstand the high pressure and high stress of the core box process, and are chemical resistant. Even very high unit counts can be consistently produced with our products.

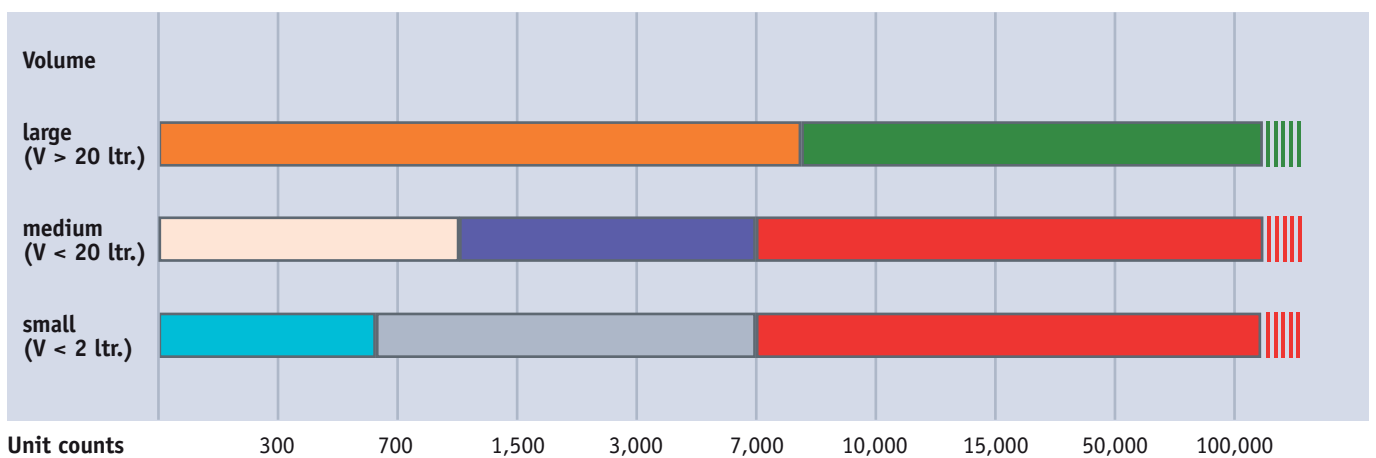

Unit counts are non-binding and based on manufacturing process. For specifications and other technical information, please see pages 11-15.

### Volume > 20 Litres

- Core box, laminated: OH 11 with KP 6 and PS 03
- Core box, laminated: OH 16 with KP 6 and PS 03

### Volume < 2 Litres

- Solid casting, fast curing: SG 130, SG 2000, SG 700
- Solid casting: GH 760
- Face casting: GM 974, VP GM 995

### Volume < 20 Litres

- Solid casting, slow curing: GM 725-7
- Face casting: GH 706, GH 730, GH 760
- Face casting: GM 974, VP GM 995

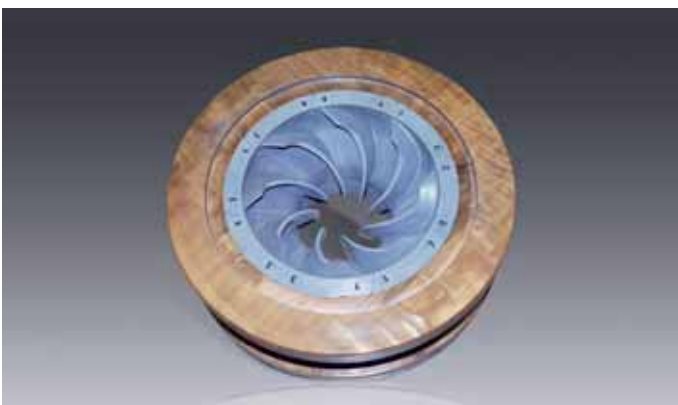

Core box made of GH 760



Core box made of GM 974

## Milled core boxes

As with the milled models, **ebalta** also has the ideal solution for choosing the right materials for milled core boxes based on unit count. All products are highly precise thanks to CNC technology, extremely abrasion resistant and consistently produce very high unit counts. The material most commonly used for highest abrasion resistance is **ebablock® K**, which was specially developed for milled core boxes.

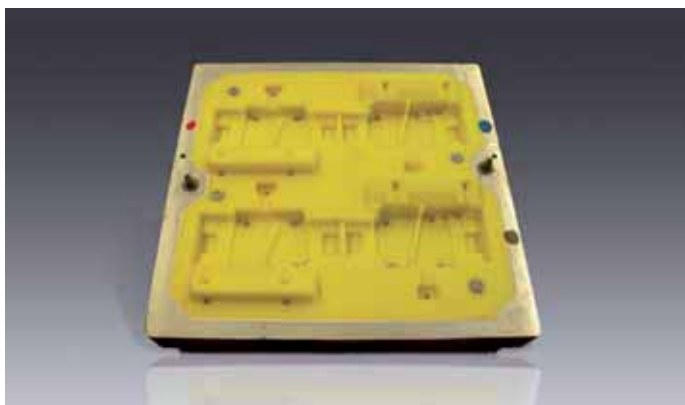
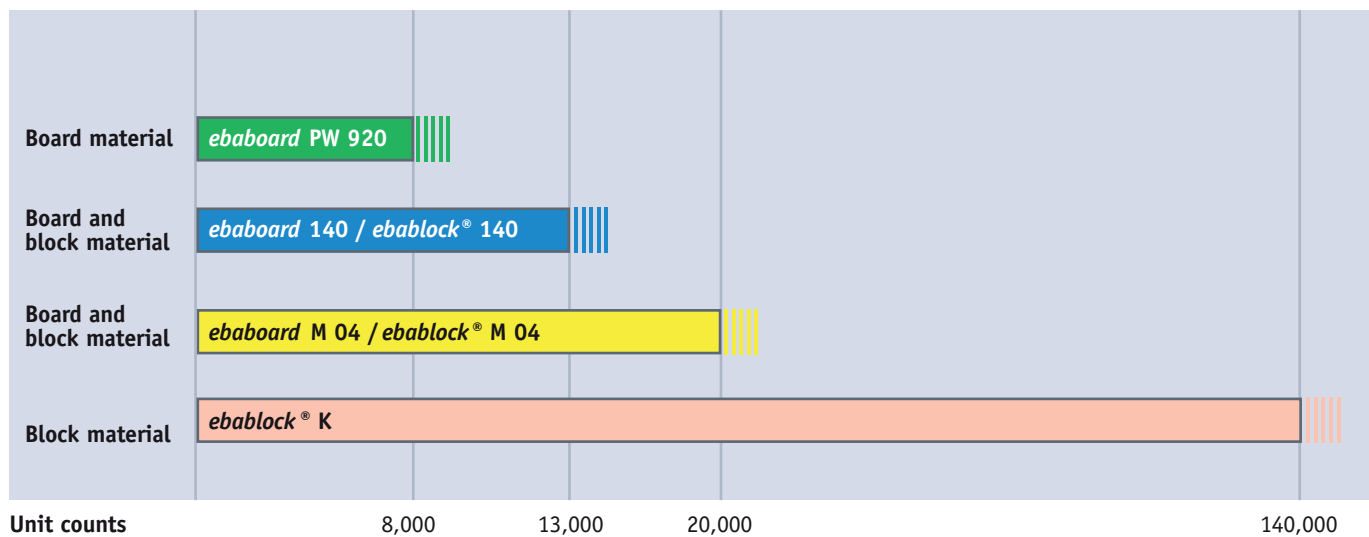

Core box made of **ebablock® M 04**



8-fold core box made of **ebablock® K** with core nests

# Negatives

No matter which fabrication technique or quality you desire, we offer well-established, high-quality products for fast fabrication of negatives.

Fabrication technique	Quality	
	Standard	High-quality
Casting	SG 700 / SG 2000	GM 725-7
Laminating	OH 4	OH 11
Milling, boards <i>ebaboard</i>	<i>ebaboard</i> 60	<i>ebaboard</i> PW 920
Milling, contour blocks <i>ebablock</i> <sup>®</sup>	<i>ebablock</i> <sup>®</sup> M 007	<i>ebablock</i> <sup>®</sup> W mineral

For specifications and other technical information, please see pages 11-17.



Negative made of GM 725-7



Negative made of OH 11 with PS 03

# Products and specifications

## Gel coats

These materials are used mainly in lay-up processes for large-surface models with a gel coat and a corresponding resin backing. Our highly versatile products are easily applied and optimally bonded with coupling paste KP 6.

Resin	OH 4	OH 6-1	OH 11	OH 16	OH 17	OH 47
Hardener	SR	SR	PUR 3	Comp. B	Comp. B	Comp. B
Colour	white	blue	red brown	light green	white	white
Mixing ratio (p. b. w.)	100 : 12.5	100 : 9	100 : 40	100 : 70	100 : 45	100 : 41
Applications	Negatives, master models, foundry patterns	Foundry patterns, core boxes, pattern plates	Foundry patterns, core boxes, pattern plates, negatives	Core boxes, foundry patterns, pattern plates	Pattern plates, foundry patterns, core boxes	Pattern plates, foundry patterns, core boxes
Material properties	versatile, very easily spread, easy to sand	very abrasion resistant, very hard, fine structure	abrasion resistant, impact resistant, polyurethane base	very abrasion resistant, hard flexible, very impact resistant	very abrasion resistant, very hard flexible, very impact resistant	very abrasion resistant, very hard flexible, very impact resistant, nontoxic
Processing data						
Viscosity at 25°C (mPas)	thixotrope	thixotrope	thixotrope	thixotrope	thixotrope	thixotrope
Density at 20°C (g/cm <sup>3</sup> )	1.40 ± 0.05	1.75 ± 0.05	1.27 ± 0.02	1.12 ± 0.02	1.18 ± 0.02	1.10 ± 0.02
Pot life 200 g / 20°C (min.)	15-20	15-20	30-40	10-15	10-15	14-20
Curing time at RT (hrs.)	3-5	5-8	3-5	6-8	8-10	8-10
Physical data						
Flexural strength (MPa)	95 ± 5	105 ± 8	80 ± 7	-	-	-
Flexural modulus (MPa)	4815 ± 300	6650 ± 400	4230 ± 250	-	-	-
Compressive strength (MPa)	100 ± 5	104 ± 8	80 ± 5	-	-	-
Impact resistance (Charpy) (kJ/m <sup>2</sup> )	10 ± 2	-	7 ± 1	-	-	-
Heat resistance						
HDT DIN EN ISO 75 B (°C)	82 ± 3	94 ± 3	72 ± 2	-	-	-
Shore hardness (Shore D)	90 ± 3	85 ± 3	88 ± 3	58 ± 3	64 ± 3	64 ± 3
Abrasion (Taber) (mg)	-	approx. 36	approx. 72	approx. 19	approx. 18	approx. 22
Type/Application wt./ Rotations	-	H 18/500/250	H 18/500/250	H 18/500/500	H 18/500/500	H 18/500/500



Pattern made of OH 11 with PS 03



Application of the surface layer

## General purpose resins and paste systems

*ebalta* general purpose resins and paste systems are the products of choice for large-surface models with high accuracy. They are pleasant to work with and contract only slightly.

Resin	AH 100	AH 110	KP 6	PS 03
Hardener	TGL*	TGL*	TGL	PS 03 Hardener
Colour	yellow transparent	yellow transparent	grey	blue
Mixing ratio (p. b. w.)	100 : 20	100 : 22	100 : 18	100 : 18
Applications	Laminating resin for fabrics, bonding resin for fillers	Laminating resin for fabrics, bonding resin for fillers	Coupling paste for epoxy resins	Core boxes, foundry patterns, negatives
Material properties	unfilled, slow curing, large volume backfilling	unfilled, high strength, very heat resistant	fiberglass-filled, heat resistant	fiberglass-filled
Processing data				
Viscosity at 25°C (mPas)	550 ± 100	1000 ± 150	thixotrope	pasty
Density at 20°C (g/cm³)	1.12 ± 0.02	1.13 ± 0.02	1.30 ± 0.05	0.92 ± 0.03
Pot life 200 g / 20°C (min.)	65-75	55-65	30-40	50-60
Curing time at RT (hrs.)	18-20	15-18	8-12	16-24
Physical data				
Flexural strength (MPa)	105 ± 5	135 ± 10	-	45 ± 4
Flexural modulus (MPa)	3000 ± 200	3300 ± 300	-	3000 ± 300
Flexural expansion at breakage (%)	4.7 ± 0.5	6.3 ± 0.7	-	2 ± 0.25
Compressive strength (MPa)	100 ± 8	115 ± 10	-	45 ± 4
Impact resistance (Charpy) (kJ/m²)	37 ± 10	16 ± 8	-	5.7 ± 1
Heat resistance				
HDT DIN EN ISO 75 B (°C)	76 ± 2	101 ± 3	-	53 ± 2
Shore hardness (Shore D)	87 ± 3	85 ± 3	-	75 ± 2

\* The specifications and physical data for the general purpose resins can be individually selected, as different hardeners are available.



Core box made of OH 11 with PS 03



Back of pattern made of OH 11 with PS 03

## Epoxy casting resins

Filled systems, chemically resistant, dimensionally accurate – epoxy casting resins from **ebalta** are suitable for many applications.

Material	GH 706	GH 723	GH 730	GH 760
<b>Hardener</b>	GL	D	BR	GL
<b>Colour</b>	blue	green	black	grey
<b>Mixing ratio (p. b. w.)</b>	100 : 10	100 : 7	100 : 10	100 : 10
<b>Applications</b>	Foundry patterns, core boxes, pattern plates	Foundry patterns, core boxes, pattern plates, bonding resin for fillers	Foundry patterns, core boxes, pattern plates, negatives	Foundry patterns, core boxes, pattern plates
<b>Material properties</b>	very abrasion resistant, fine structure, very hard	low viscosity, very well castable	versatile, high strength	high dimensional accuracy, abrasion resistant, high strength, very good sliding properties
<b>Processing data</b>				
Viscosity at 25°C (mPas)	10000 ± 2000	1500 ± 250	8000 ± 1500	9500 ± 1000
Density at 20°C (g/cm <sup>3</sup> )	2.05 ± 0.05	1.75 ± 0.05	2.20 ± 0.05	2.20 ± 0.05
<b>Pot life 200 g/20°C (min.)</b>	<b>30-40</b>	<b>55-65</b>	<b>35-45</b>	<b>45-55</b>
<b>Curing time at RT (hrs.)</b>	<b>12-16</b>	<b>16-20</b>	<b>12-14</b>	<b>18-24</b>
<b>Physical data</b>				
Flexural strength (MPa)	83 ± 2.6	65 ± 5	80 ± 5	100 ± 10
Flexural modulus (MPa)	8424 ± 380	6250 ± 400	7800 ± 400	7250 ± 500
Compressive strength (MPa)	104 ± 4	70 ± 7	105 ± 10	120 ± 10
Impact resistance (Charpy) (kJ/m <sup>2</sup> )	7 ± 1	6.3 ± 0.5	6 ± 2	9 ± 1.5
Heat resistance HDT DIN EN ISO 75 B (°C)	67 ± 2	46 ± 2	64 ± 2	63 ± 2
Shore hardness (Shore D)	90 ± 3	87 ± 3	90 ± 3	89 ± 3
Coefficient of thermal expansion (10 <sup>-6</sup> K <sup>-1</sup> )	approx. 53	approx. 63	approx. 42	approx. 45
Abrasion (Taber) (mg) Type/Application wt./ Rotations	-	-	approx. 19 CS 17/500/500	approx. 20 CS 17/500/500



Pattern made of GH 760

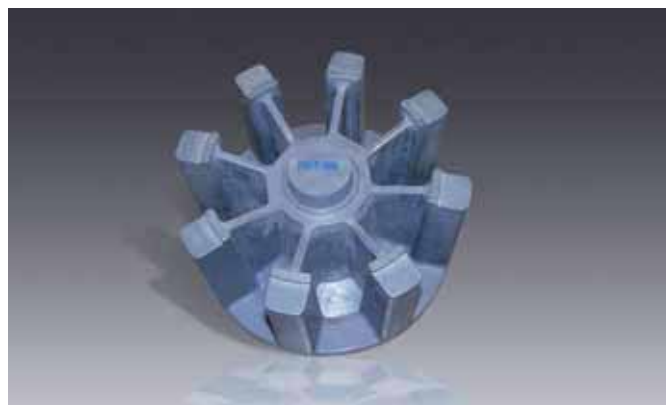

Pattern made of GH 760

## Polyurethane casting resins

Polyurethanes possess a wide range of properties, from very abrasion resistant elastomers to high-strength casting resins. Their low exothermic reactivity makes them dimensionally accurate and castable at high volumes. *ebalta* also offers nontoxic, very abrasion resistant elastomers.

Material	GM 708	GM 725-7	GM 974	GM 975	VP GM 995
<b>Hardener</b>	PUR 4	PUR 13	Comp. B	Comp. B	Comp. B
<b>Colour</b>	brown	beige	reddish transparent	white	beige
<b>Mixing ratio (p. b. w.)</b>	100 : 75	100 : 15	100 : 65	100 : 36	100 : 60
<b>Applications</b>	Foundry patterns, negatives	Foundry patterns, pattern plates, core boxes, negatives	Core boxes, foundry patterns, pattern plates	Foundry patterns, pattern plates, core boxes	Core boxes, foundry patterns, pattern plates
<b>Material properties</b>	unfilled, slow curing, high filler content possible	castable in high volumes, high dimensional accuracy, good flow properties, well workable, long pot life	very abrasion resistant, hard flexible	very abrasion resistant, very hard flexible	very abrasion resistant, hard flexible, very well castable, nontoxic
<b>Processing data</b>					
Viscosity at 25°C (mPas)	500 ± 100	6000 ± 500	2800 ± 500	6500 ± 700	950 ± 200
Density at 20°C (g/cm <sup>3</sup> )	1.20 ± 0.03	1.75 ± 0.05	1.09 ± 0.02	1.07 ± 0.01	1.12 ± 0.03
<b>Pot life 200 g / 20°C (min.)</b>	<b>45-60</b>	<b>40-50</b>	<b>20-25</b>	<b>12-15</b>	<b>19-23</b>
<b>Curing time at RT (hrs.)</b>	<b>16-24</b>	<b>12-16</b>	<b>10-12</b>	<b>8-10</b>	<b>14-16</b>
<b>Physical data</b>					
Flexural strength (MPa)	110 ± 10	56 ± 5	-	-	-
Flexural modulus (MPa)	2250 ± 250	8025 ± 800	-	-	-
Compressive strength (MPa)	80 ± 8	76 ± 8	-	-	-
Impact resistance (Charpy) (kJ/m <sup>2</sup> )	58 ± 8	3.6 ± 0.5	-	-	-
Heat resistance					
HDT DIN EN ISO 75 B (°C)	76 ± 3	51 ± 2	-	-	-
Shore hardness (Shore D)	82 ± 3	87 ± 3	60 ± 3	70 ± 3	68 ± 3
Coefficient of thermal expansion (10 <sup>-6</sup> K <sup>-1</sup> )	-	approx. 52	-	-	-
Abrasion (Taber) (mg)	-	-	approx. 27	approx. 10	approx. 25
Type/Application wt./Rotations	-	-	H 18 / 500 / 500	H 18 / 500 / 500	H 18 / 500 / 500



Pattern made of GM 725-7



Pattern made of GM 725-7

## Fast casting resins

For decades the fast curing resins from **ebalta** have been a force to be reckoned with in the field of foundry tooling. Fast, accurate and inexpensive, they are easy and economical to use.

Material	SG 140	SG 2000 A	SG 700
<b>Hardener</b>	PUR 11	SG 2000 B	PUR 5
<b>Colour</b>	ivory	ivory	blue
<b>Mixing ratio (p. b. w.)</b>	100 : 100	100 : 100	100 : 15
<b>Applications</b>	Foundry patterns, core boxes, pattern plates, negatives	Foundry patterns, core boxes, pattern plates, negatives	Foundry patterns, core boxes, negatives
<b>Material properties</b>	unfilled, very low viscosity, high filler content possible	unfilled, very low viscosity, high filler content possible	filled, easily cast, fine structure, dimensionally accurate
<b>Processing data</b>			
Viscosity at 25°C (mPas)	75 ± 20	50 ± 5	900 ± 100
Density at 20°C (g/cm <sup>3</sup> )	1.10 ± 0.02	1.10 ± 0.02	1.70 ± 0.05
<b>Pot life 200 g /20°C (min.)</b>	<b>2.5-3.5</b>	<b>2.5-3.5</b>	<b>5-6</b>
<b>Curing time at RT (hrs.)</b>	<b>0.5-1.5</b>	<b>0.5-1</b>	<b>1-2</b>
<b>Physical data</b>			
Flexural strength (MPa)	60 ± 5	57 ± 5	40 ± 4
Flexural modulus (MPa)	1000 ± 100	1500 ± 100	4500 ± 400
Compressive strength (MPa)	47 ± 5	45 ± 5	60 ± 5
Impact resistance (Charpy) (kJ/m <sup>2</sup> )	26 ± 2.5	24 ± 4	4 ± 0.5
Heat resistance			
HDT DIN EN ISO 75 B (°C)	84 ± 3	86 ± 3	78 ± 3
Shore hardness (Shore D)	72 ± 2	72 ± 2	83 ± 3



Pattern made of SG 2000 with filler F-A



Pattern made of SG 700

# ebaboard: board materials for foundry patterns

The **ebaboard** product series comprises board materials available in various thicknesses. **ebaboard** products have many advantages: dimensional accuracy and stability, durability, and highly stable edges. You benefit through superb machinability and very little dust build-up.

Material	<b>ebaboard 60</b>	<b>ebaboard S</b>	<b>ebaboard M 04</b>	<b>ebaboard PW 920</b>	<b>ebaboard 140</b>
Colour	red brown	red brown	yellow	green	blue
Applications	Master models, negatives, core centres	Master models, foundry patterns, core centres	Foundry patterns, core boxes, pattern plates	Foundry patterns, core boxes, pattern plates, negatives	Foundry patterns, core boxes, pattern plates
Material properties	dense surface, very easily worked	dense surface, fine structure, very easily worked	very abrasion resistant, highly impact resistant, dense surface, good edge strength	very easily worked, good edge strength, dense surface, impact resistant, no generation of dust	low thermal expansion, highly abrasion resistant, fine structure, easily worked, very good edge strength
Density at 20°C (g/cm <sup>3</sup> )	0.65 ± 0.02	0.70 ± 0.02	1.20 ± 0.02	1.21 ± 0.05	1.38 ± 0.03
Delivery dimensions (mm)	1500 x 500 x 25 1500 x 500 x 50 1500 x 500 x 75 1500 x 500 x 100 1500 x 500 x 200	1500 x 500 x 25 1500 x 500 x 50 1500 x 500 x 75 1500 x 500 x 100 1500 x 500 x 150 1500 x 500 x 200	1000 x 500 x 50 1000 x 500 x 75 1000 x 500 x 100	1000 x 500 x 30 1000 x 500 x 50 1000 x 500 x 75 1000 x 500 x 100	1000 x 500 x 50 1000 x 500 x 75 1000 x 500 x 100
<b>Physical Data</b>					
Flexural strength (MPa)	17 ± 3	25 ± 3	120 ± 5	72 ± 5	109 ± 5
Flexural modulus (MPa)	-	-	2950 ± 300	1807 ± 150	4175 ± 100
Compressive strength (MPa)	17 ± 3	24 ± 3	90 ± 5	56 ± 5	102 ± 5
Impact resistance (Charpy) (kJ/m <sup>2</sup> )	5 ± 1	6 ± 1	66 ± 9	25 ± 3	19.5 ± 2
Heat resistance					
HDT DIN EN ISO 75 B (°C)	70 ± 3	67 ± 2	87 ± 3	90 ± 3	87 ± 2
Shore hardness (Shore D)	62 ± 3	65 ± 3	84 ± 3	79 ± 2	85 ± 3
Coefficient of thermal expansion (10 <sup>-6</sup> K <sup>-1</sup> )	approx. 50	approx. 55	approx. 77	approx. 109	approx. 65
Abrasion (Taber) (mg)	-	-	approx. 105	approx. 101	approx. 62
Type/Application wt./ Rotations	-	-	H 18/500/500	H 18/500/250	H 18/500/500

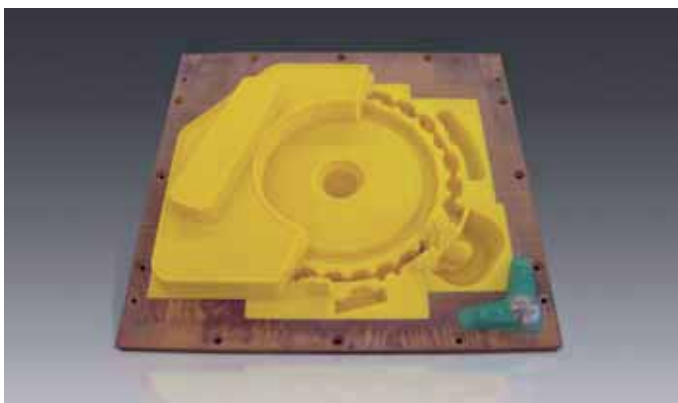

Pattern made of **ebaboard M 04**



Pattern made of **ebaboard PW 920**

# ebablock®: the net-sized contour block material for jointless foundry patterns

Customized block material for easier and more precise machining: **ebablock®** provides you with an individually created product to your specifications for the manufacture of jointless foundry patterns.

Material	ebablock® M 007	ebablock® M 04	ebablock® K	ebablock® 140	ebablock® W mineral
<b>Colour</b>	brown	yellow	salmon pink	blue	beige
<b>Applications</b>	Master models, negatives, core centres, foundry patterns	Foundry patterns, core boxes, pattern plates	Core boxes, foundry patterns, pattern plates	Foundry patterns, core boxes, pattern plates	High-quality negatives, foundry patterns
<b>Material properties</b>	dense surface, fine structure, very easily worked, no generation of dust	very abrasion resistant, highly impact resistant, dense surface, good edge strength	very high abrasion resistance, very impact resistant, dense surface, very easily worked, no generation of dust	low thermal expansion, highly abrasion resistant, fine structure, easily worked, very good edge strength	very low thermal expansion, high strength, easily worked, fine structure
Density at 20°C (g/cm³)	0.80 ± 0.02	1.20 ± 0.02	1.20 ± 0.02	1.38 ± 0.03	1.76 ± 0.03
<b>Physical Data</b>					
Flexural strength (MPa)	49 ± 4	120 ± 5	-	109 ± 5	72 ± 8
Flexural modulus (MPa)	2770 ± 250	2950 ± 300	-	4175 ± 100	9000 ± 300
Compressive strength (MPa)	41 ± 4	90 ± 5	-	102 ± 5	110 ± 10
Impact resistance (Charpy) (kJ/m²)	6.0 ± 1	66 ± 9	-	19.5 ± 2	6.0 ± 1.5
Heat resistance HDT DIN EN ISO 75 B (°C)	81 ± 3	87 ± 3	-	87 ± 2	66 ± 2
Shore hardness (Shore D)	73 ± 3	84 ± 3	62 ± 3	85 ± 3	90 ± 3
Coefficient of linear expansion (10 <sup>-6</sup> K <sup>-1</sup> )	approx. 60	approx. 77	approx. 163	approx. 65	approx. 39
Abrasion (Taber) (mg)	-	approx. 105	approx. 32	approx. 62	approx. 160
Type/Application wt./Rotations	-	H 18/500/500	H 18/500/500	H 18/500/500	H 18/500/250

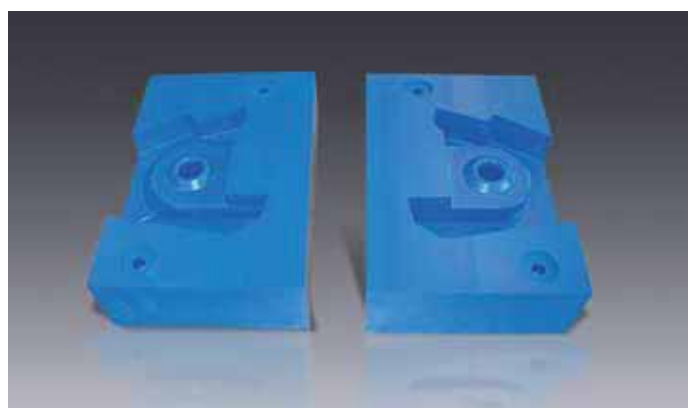

Core box made of **ebablock® 140**

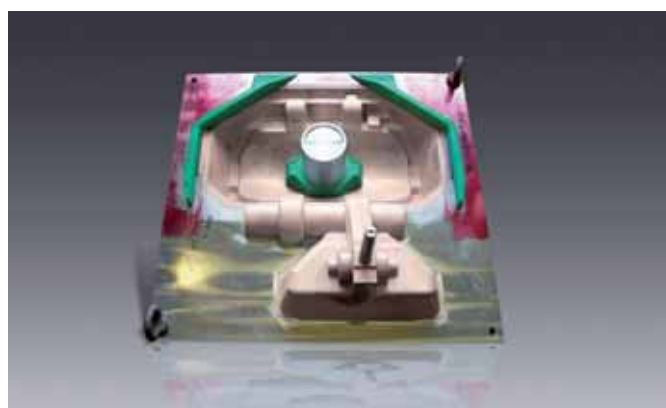

Pattern made of **ebablock® W mineral**

# *ebablock®: the net-sized contour block material for jointless foundry patterns*

**ebablock®** can be used for a variety of applications. Our experts are happy to advise you from the choice of materials to the final foundry pattern.

## *A new technology for foundry tooling*

**ebablock®** is produced in close collaboration with the customer. Available in block thicknesses of up to 500 mm, **ebablock®** can be custom made into blocks or net-sized contour blocks in accordance with your individual specifications. An outstanding performance feature is the excellent surface quality, resulting from the homogeneously cast and stress-free tempered blocks with no adhesive joints.

## *Higher performance, point by point*

Every **ebablock®** makes foundry patterning easier and more efficient for you.

- You receive the block material to your specifications and dimensions, e.g. based on the size of the moulding box
- Models, negatives and patterns are jointless
- The net-sized contour cuts down milling times considerably
- Each **ebablock®** possesses outstanding dimensional stability
- No need to adhere anything; there are no adhesive joints
- Noticeable reductions in waste and refinishing

Altogether these plus points add up to one thing for you: higher quality foundry patterns.

## *High performance in customer support*

The **ebablock®** product series includes comprehensive customer support, from your first contact with us to the completion of your job.

- We accompany your project from beginning to end
- We promptly submit to you a precise and individualised offer
- We create your **ebablock®** based on your specifications, regardless of whether you provide them as a CAD file or a sketch
- We manufacture the moulds you need
- We provide you with the right milling parameters for processing your **ebablock®**
- **ebablock®** includes a comprehensive line of other products, for example, repair resins, which make it much easier to make modifications.

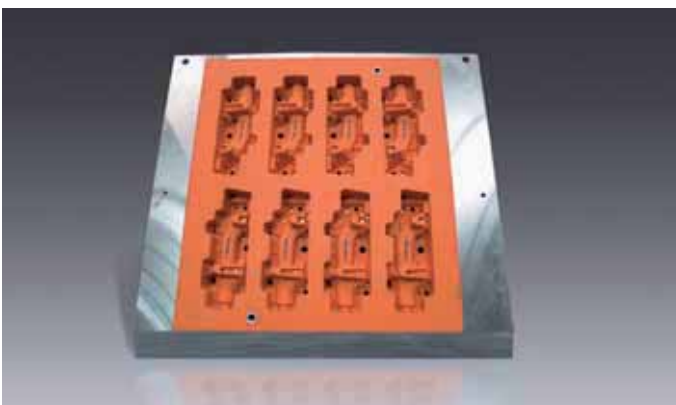

Core box made of **ebablock® K**



Core box made of **ebablock® M 04**

## Step by step to *ebablock*<sup>®</sup>

It's easy to receive your individually manufactured block material. We will ship your ready-to-machine *ebablock*<sup>®</sup>, depending on the complexity and volume of your order as quickly as possible.

### 1. Your order

You send us a drawing or CAD file with the specifications and dimensions for the *ebablock*<sup>®</sup> you require.

### 2. Mould making

We make a mould based on this data.

### 3. Mixing materials

We convert the raw material into an homogeneous mixture to meet your requirements 100%.

### 4. Casting the *ebablock*<sup>®</sup>

Then we cast your individual block material. Our vacuum techniques prevent air bubbles from forming in the castings.

### 5. Postcuring the *ebablock*<sup>®</sup>

Once it has been cast, the *ebablock*<sup>®</sup> is postcured with an electronically controlled tempering process to eliminate stresses from the block and achieve optimal strength.

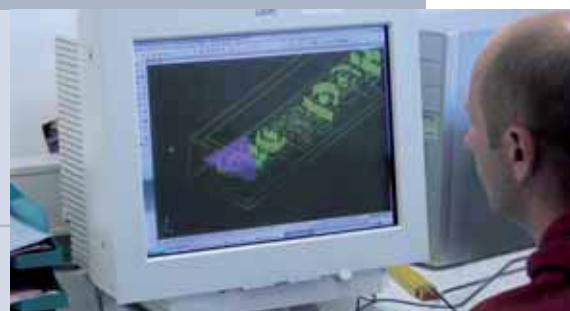

## Other products from ebalta

### *eba•ject ejector system for core boxes*

*This patented innovation from ebalta provides for flawless moulding components, making repairs and production down times a thing of the past. eba•ject guarantees smooth production to the very last unit.*

#### *Simple technology – optimal results*

One investment that more than pays for itself: the new **eba•ject** ejector system from **ebalta** prevents all the technical problems that usually result with high unit counts. **eba•ject** compensates simply and precisely for the inevitable expansion differences between the tooling set-up and ejector. The result: flawless moulded components and a smooth production run free of disruptions. **eba•ject** is also available for use with inorganic materials as well as with an air valve. **eba•ject** is available in sizes 6, 8, 10, 12, 14 and 16 mm.

#### *eba•ject – all the highlights at a glance*

- Saves lots of time
- Ejector is easy to adjust
- No down times for repairs
- Protected against torsion
- Highly accurate for repetitive processes
- A very secure investment due to greater longevity
- Reusability makes it very economical

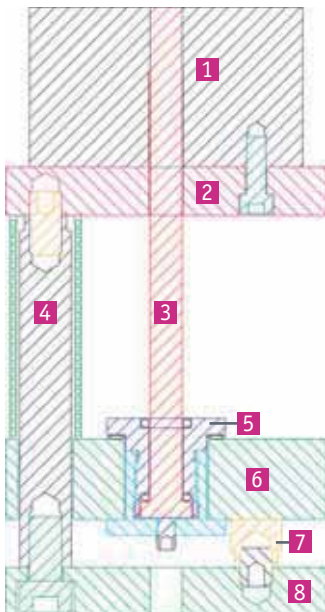

1. Core box
2. Assembly base
3. Standard ejector
4. Guide pin for pressure plate
5. **eba•ject**
6. Pressure plate
7. Pressure plate stop
8. Base

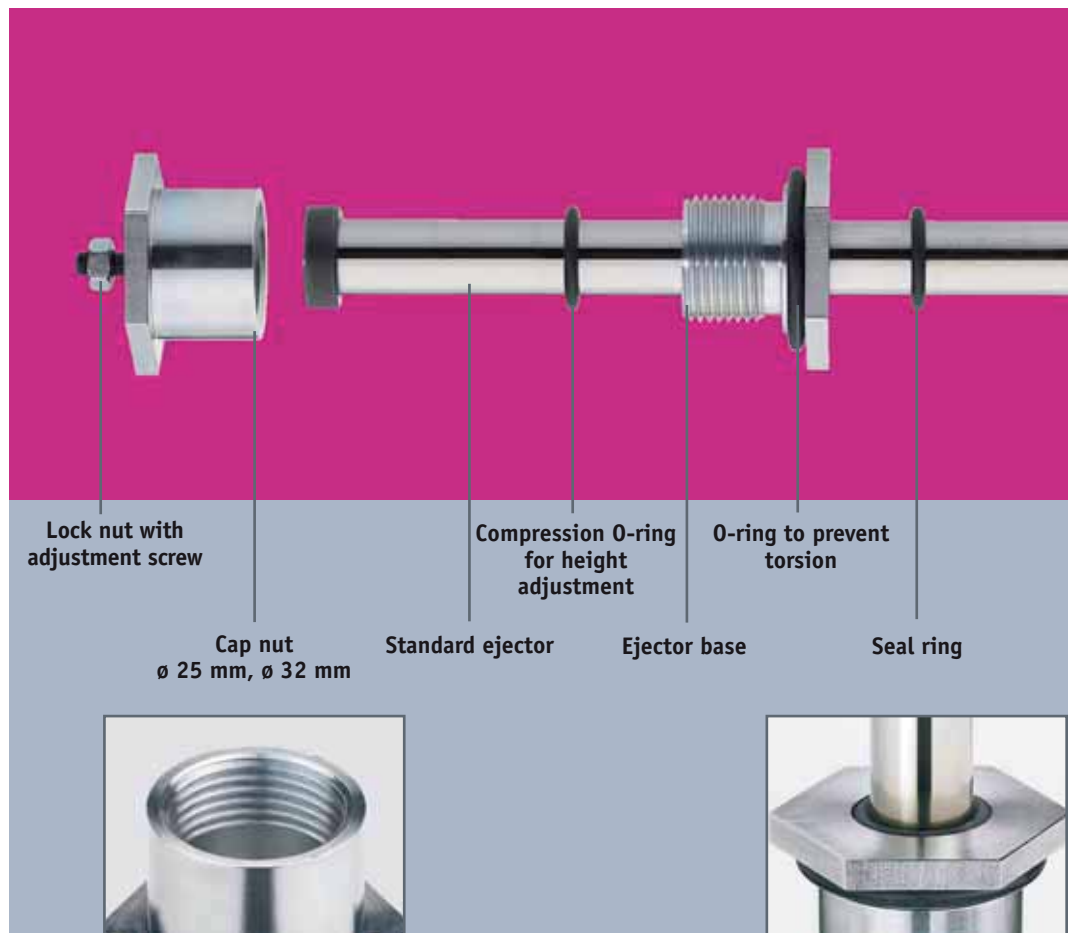

## eba•safe fastening system

No more deformations, no more blocks sliding out the side, no more burring on the edges: **eba•safe** sits perfectly on the base plate. For optimal production results with all conventional block materials and tooling resins.

### Better safe than sorry

**eba•safe** is a collar bushing that prevents the contour from becoming deformed and the core box from sliding out the side. **eba•safe** is attached to the block material from below for a firm hold. Your production run turns out perfectly formed components, unit for unit.

### Perfect results, time after time

**eba•safe** is new because the collar bushing provides friction-fitted hold on the base plate. Unlike conventional screw joints, **eba•safe** counteracts the forces that can cause deformations, rendering them harmless to the material. With its Allen bolt, **eba•safe** is easy to screw in. The material remains completely undamaged, even if the mold has been dismantled multiple times.

**eba•safe** is available in sizes 6, 8, 10, 12 and 16 mm (internal thread).

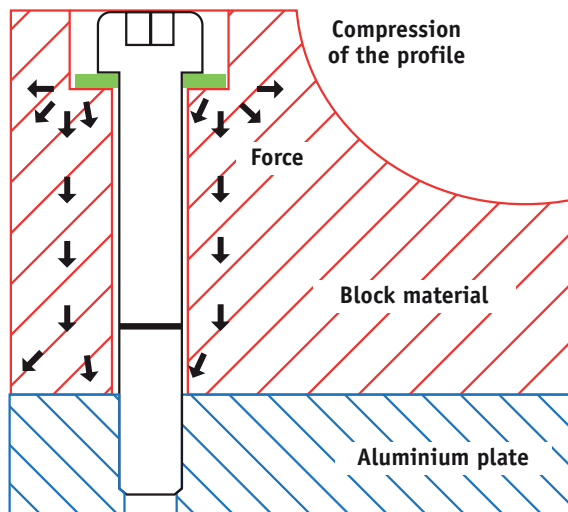

Conventional screw joint

### The perfect duo for greater efficiency: **eba•safe** und **eba•ject**

Unbeatably economical, **eba•safe** combined with **eba•ject** provides for smooth and efficient production. This duo prevents down times and damaged components from the start, while ensuring consistently reliable production quality.

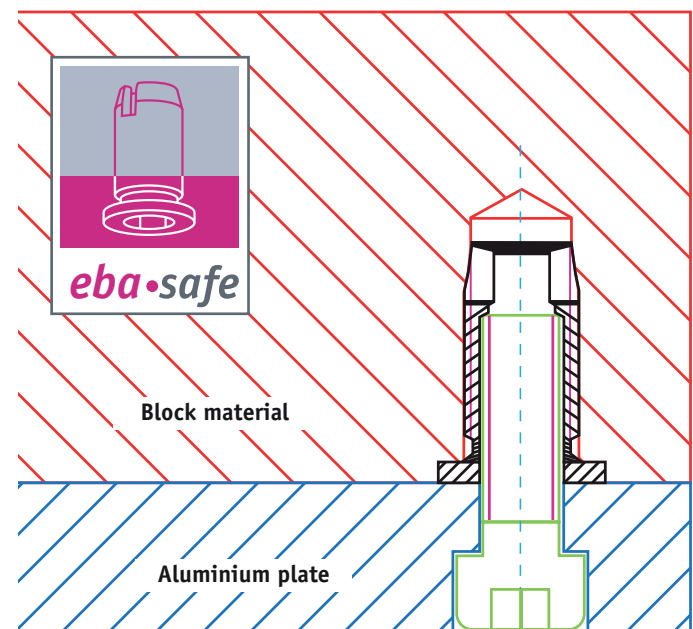

**eba•safe** screw joint

## ebalta ancillaries

ebalta offers a complete range of production aids for use in every stage of foundry tooling.

<i>Adhesives for boards</i>	Two-component system for adhering <b>ebaboard</b> and <b>ebablock</b> <sup>®</sup> in matching colours	Very strong Easily worked Moisture resistant
<i>Repairing compounds for <b>ebaboard PW 920</b>, <b>ebablock</b><sup>®</sup> <b>K</b>, <b>ebablock</b><sup>®</sup> <b>M 04</b>, <b>ebablock</b><sup>®</sup> <b>140</b></i>	Two-component system for repairing <b>ebaboard</b> and <b>ebablock</b> <sup>®</sup>	Very strong Easily worked
<i>Fast adhesive AD 51</i>	Single-component adhesive for adhering <b>ebaboard</b> and <b>ebablock</b> <sup>®</sup>	Solvent-free Very fast curing Transparent
<i>Repairing paste aluminium</i>	Two-component system for repairing metal and synthetic resin tools and models (also for aluminium and iron casting parts)	Aluminium-filled Very resistant to high temperatures
<i>Fast curing model paste</i>	Two-component polyester-based putty for repairs and bonding	Very easy to sand Fine structure Very good surface adhesion
<i>T1-1 mould release agent</i>	For release of component surfaces (suitable for use with polyurethane, epoxy resins and polyester-based materials)	Very short drying time Easy to polish Apply with brush or spray
<i>Sealer</i>	Primer for sealing porous surfaces (wood, plaster), creates highly smooth surfaces	Fast drying Apply with brush or spray
<i>Graphite paint</i>	2-components paint for resin- and wooden moulds, aluminium moulds	Protection to sand adhesion Easy demoulding
<i>Wax sheets</i>	Normal and thermostable sheets, various types available in different thicknesses	Fast and easy handling Adhesive-backed
<i>Fillers</i>	Mineral-based and metallic fillers available as powders and granules	

Developed specially for **ebalta** materials, this multi-faceted spectrum of ancillary products make it as easy as possible for you to handle our materials.

<b>Brushes</b>	
Flat brushes	10 / 20 / 30 mm
Gussow brush	12 mm
Gussow bristle brush	20 mm
<b>Stirrers</b>	
Star stirrer	90 / 130 mm
Spiral stirrer	70 / 90 mm
<b>Gloves</b>	
Latex gloves with/without powder	S / M / L / XL
Vinyl gloves without powder	S / M / L / XL
Nitrile gloves without powder	M / L / XL
Cotton gloves	One size fits all
<b>Mixing Cups</b>	
Plastic mixing cup	350 / 860 / 2100 ml
Cardboard mixing cup	Small / Large
<b>Adhesives</b>	
Dries-in-seconds adhesive AD 51	20 g bottle
Spray adhesive	400 ml can
<b>Plasticine (kneadable wax)</b>	
Superplasticine	Yellow
Plasticine	Red
Plasticine	White
<b>Miscellaneous</b>	
Cleaning solvent	5 / 25 kg canister
Preservative spray	0.23 kg can



*tooling resins   blocks   ancillaries   silicones*

*Foundry tooling*

*Design model making*

*Rapid Prototyping*

*Mould and tool making*

*Composites*

*Electrical encapsulation*

*Further applications*

*If you have any questions concerning technical and production issues, please call us anytime to make an appointment with our experts.*

**ebalta** UK Limited  
B2 Langham Park, Trent Lane,  
Castle Donington,  
Derbyshire. DE74 2UT  
t: +44 1332 814700  
f: +44 1332 814775  
e: [info@ebalta.co.uk](mailto:info@ebalta.co.uk)  
w: [www.ebalta.co.uk](http://www.ebalta.co.uk)

**ebalta** Kunststoff GmbH  
w: [www.ebalta.de](http://www.ebalta.de)

**ebalta**  
Solution takes shape